

In-line Centrifugal Fan Range

Commercial Range

CFD200/220 SCF200



- Providing solutions for a wide range of domestic, commercial and industrial applications, the CFD200/220 in-line fans have been designed for use with suspended ceilings.
- Powerful, yet quiet and unobtrusive, the CFD200/220 units have extract rates of 110m³/hr (31 litres per second).
- The CFD series is suitable for a wide range of applications including bathrooms, toilets, shower rooms and utility rooms.
- The CFD series is fitted with backward curved centrifugal impellers for a large airflow against the high pressures caused by longer lengths of ducting and resistance by grilles.
- There is an extensive range of ventilation accessories available to cover most in-line ducting systems.
- The CFD200 units are manufactured using high impact ABS thermoplastics for strength and durability, aesthetics and easy cleaning.
- A spring operated, non-return flap is built into the discharge spigot to prevent backdraughts.
- Available with or without mounting bracket.
- The CFD220 has all the features of the CFD200 unit, but has the additional benefit of a 120mm outlet, thus making it suitable for 125mm (5") ducting systems.
- Power to the CFD200/220 range is provided by a single phase induction motor with pre-oiled bearings for a long, maintenance-free life.
- The SCF200 series in-line centrifugal fan kits comprises of the 100mm centrifugal in-line fan unit, 6 metres of PVC ducting and wall grilles.
- Designed to comply with the Building Regulations on Ventilation (F1).

Technical Details

Cat. No.	Product type
CFD200	Standard model without bracket
CFD200S	Standard model with bracket
CFD200T	Timer model with bracket
CFD220	Standard model without bracket
CFD220S	Standard model with bracket
CFD220T	Timer model with bracket
SCF200S	Standard model in-line fan kit (100mmØ)
SCF200T	Timer model in-line fan kit (100mmØ)

Dimensions (mm)

PRODUCT	A	B	C	D
CFD200	155	100Ø	195	258
SCF200	155	100Ø	195	258
CFD220	155	120Ø	195	258

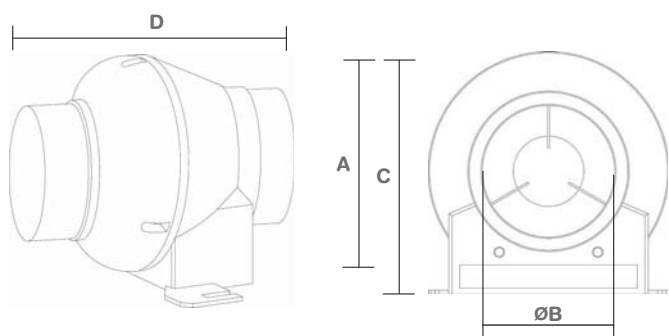

Performance Graph

CFD200/220/SCF200

110m³/hr, 31 litres per second

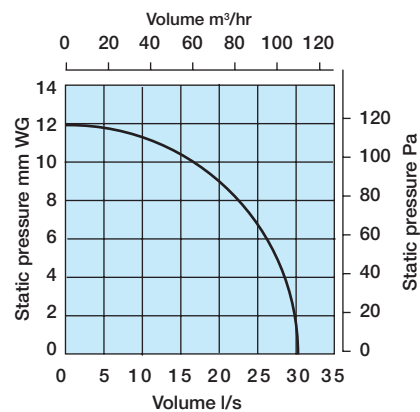

Typical Installation

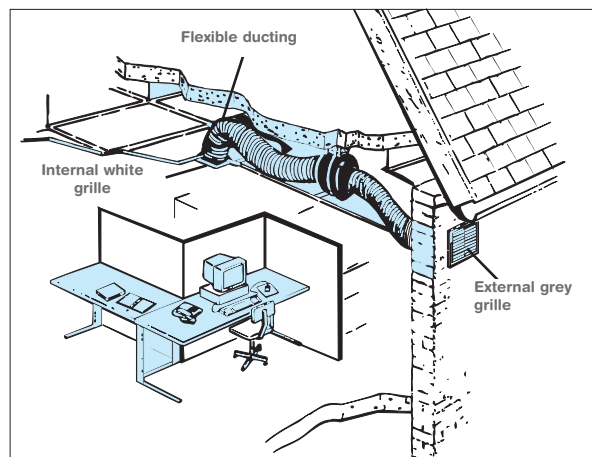

Packaging

CFD200/220 Series in outers of 5 measuring 200mm x 300mm x 240mm - weight 8kgs

SCF200 Series in outers of 5. For packaging dimensions, please contact our technical department

Electrical

220-240V - AC. 50Hz . Single phase consuming 18W on the CFD200/220 and SCF200. All wiring must comply with the current IEE regulations. A double pole isolating switch, having a contact separation of at least 3mm in all poles, must be used with a 3 amp fuse fitted.

Additional Data

CFD200/220 SCF200

Maximum pressure 120p.a.

Fan speed:1400r.p.m.

Sound volume:45.0dB(A)

Maximum operating temperature: 40°C